

Varian Vacuum Technologies

121 Hartwell Avenue
Lexington, MA 02421-3133
(781) 861-7200
(800) 8-VARIAN



VARIAN

HS-32

Diffusion Pump

Instruction Manual

Manual No. 6999-01-132
Revision G
May 2000

Sales and Service Offices

America

Varian Vacuum Technologies

121 Hartwell Avenue
Lexington, MA 02421,
USA

Tel: (781) 861 7200

Fax: (781) 860 5437

Toll Free: 1 (800) 882 7426

Argentina

Varian Argentina Ltd.

Sucursal Argentina
Av. Ricardo Balbin 2316
1428 Buenos Aires
Argentina

Tel: (54) 1 783 5306

Fax: (54) 1 786 5172

Australia

Varian Australia Pty., Ltd.

6/81 Frenchs Forest Road
Frenchs Forest, NSW 2086
Australia

Tel: (61) 2 9975 8805

Fax: (61) 2 9452 2600

Brazil

Varian Industria e Comercio Ltda.

Avenida Dr. Cardoso de Mello 1644
Vila Olimpia
Sao Paulo 04548 005
Brazil

Tel: (55) 11 820 0444

Fax: (55) 11 820 9350

Canada

Varian Canada

6705 Millcreek Drive, Unit 5
Mississauga, Ontario L5N 5R9
Canada

Tel: (905) 819 8188

Fax: (905) 819 8348

China

Varian China Ltd.

Room 1201, Jinyu Mansion
No. 129A Xuanwumen Xidajie
Xicheng District
Beijing 100031
P.R. China

Tel: (86) 10 6641 1530

Fax: (86) 10 6641 1534

Varian Shanghai

Service Station

716 Yishan Road Shanghai
P.R. China 200233

Tel: (86) 21 6483 5576

Fax: (86) 21 6485 9031

England

Varian Ltd.

28 Manor Road
Walton-On-Thames
Surrey KT 12 2QF
England

Tel: (44) 1932 89 8000

Fax: (44) 1932 22 8769

France

Varian s.a.

7 avenue des Tropiques
Z.A. de Courtaboeuf – B.P. 12
Les Ulis cedex (Orsay) 91941
France

Tel: (33) 1 69 86 38 38

Fax: (33) 1 69 28 23 08

Germany

Varian GmbH

Alsfelder Strasse 6
Postfach 11 14 35
64229 Darmstadt
Germany

Tel: (49) 6151 703 353

Fax: (49) 6151 703 302

Hong Kong

Varian Technologies Asia, Ltd.

Rm 2611 Concordia Plaza
New Mandarin Plaza
1 Science Museum Rd.,
Tsimshatsui East, Kowloon
Hong Kong

Tel: (852) 26206173

Fax: (852) 26206338

India

Varian India PVT LTD

1010 Compotent House
7, Nangal Raya Business Centre
New Delhi 110 046
India

Tel: (91) 11 5548444

Fax: (91) 11 5548445

Italy

Varian Vacuum Technologies

via Fili Varian 54
10040 Leini, (Torino)
Italy

Tel: (39) 011 997 9111

Fax: (39) 011 997 9350

Japan

Varian Vacuum Technologies

Sumitomo Shibaura
Building, 8th Floor
4-16-36 Shibaura
Minato-ku, Tokyo 108
Japan

Tel: (81) 3 5232 1253

Fax: (81) 3 5232 1263

Korea

Varian Technologies Korea, Ltd

Shinsa 2nd Bldg. 2F
966-5 Daechi Dong
Kangnam Gu, Seoul
Korea 135-280

Tel: (82) 2 3452 2452

Fax: (82) 2 3452 2451

Netherlands

Varian Vacuum Technologies

Rijksstraatweg 269 H,
3956 CP Leersum
The Netherlands

Tel: (31) 343 469910

Fax: (31) 343 469961

Mexico

Varian S.A.

Concepcion Beistegui No 109
Col Del Valle
C.P. 03100
Mexico, D.F.

Tel: (52) 5 523 9465

Fax: (52) 5 523 9472

Singapore

Varian Asia, Ltd.

1123 Serangoon Road
#03-02

Singapore 328207

Tel: (65) 296 9688

Fax: (65) 296 9733

Spain

Varian Iberica

Avda Pedro Diez 25
28019 Madrid
Spain

Tel: (34) 91 4727612

Fax: (34) 91 4725001

Russia

Varian Moscow

19A Khlebny per
121019 Moscow
Russia

Tel: (70) 95 9374280

Fax: (70) 95 9374281

Taiwan

Varian Technologies Asia Ltd.,

Taiwan Branch

18F-13 No.79, Hsin Tai Wu Road
Sec. 1, Hsi Chih
Taipei Hsien
Taiwan

Tel: (886) 2 2698 9555

Fax: (886) 2 2698 9678

Internet Users:

Visit us on the web at:
www.eVarian.com

Representatives in most countries



VARIAN

SAFE INCORPORATION OF VARIAN DIFFUSION PUMPS INTO VACUUM SYSTEMS IS THE RESPONSIBILITY OF THE SYSTEMS DESIGNER. TAKE APPROPRIATE ACTION THROUGH REDUNDANCY, AND/OR OTHER SAFEGUARDS TO PROTECT PERSONNEL AND PROPERTY FROM THE HAZARDS DESCRIBED BELOW AND IN THE INSTALLATION, OPERATION, AND MAINTENANCE INSTRUCTION MANUAL. SAFE OPERATION IS THE RESPONSIBILITY OF THE USING ORGANIZATION AND ITS PERSONNEL. READ THE INSTRUCTION MANUAL AND UNDERSTAND HOW TO AVOID HAZARDS PRIOR TO OPERATING THE DIFFUSION PUMP. ALL PERSONS WHO WORK WITH OR ARE EXPOSED TO DIFFUSION PUMPS OR EQUIPMENT WHICH UTILIZES SUCH PUMPS OR DIFFUSION PUMP FLUID MUST TAKE PRECAUTIONS TO PROTECT THEMSELVES AGAINST POSSIBLE SERIOUS BODILY INJURY OR DEATH. DO NOT BE CARELESS AROUND SUCH PRODUCTS.

THESE SHEETS AND THE INSTALLATION, OPERATION, AND MAINTENANCE INSTRUCTIONS CAN HELP YOU TO OPERATE THIS PUMP SAFELY AND EFFICIENTLY. READ THEM. SPECIAL OPERATING CONSIDERATIONS AND PRECAUTIONS WILL BE FOUND IN THE OPERATION INSTRUCTIONS. UNINFORMED OR CARELESS OPERATION OF THIS PUMP CAN RESULT IN POOR PERFORMANCE, DAMAGE TO THE PUMP OR OTHER PROPERTY, SERIOUS BODILY INJURY, AND POSSIBLE DEATH.

USERS OF THIS EQUIPMENT SHOULD BE ALERT TO TWO LEVELS OF HAZARDS IDENTIFIED BY THE FOLLOWING SYMBOLS:

▲ WARNING

Warnings are used when failure to observe instructions or precautions could result in injury or death to humans.

▲ CAUTION

Cautions are used when failure to observe instructions could result in significant damage to equipment and/or facilities.

Designers of systems which utilize diffusion pumps must design out hazards wherever possible; provide guards, safety features, and interlocks for hazards which cannot be designed out; warn with respect to hazards which cannot be designed out and which remain after utilizing guards, safety features, and interlocks; and lastly, provide procedures and instructions on proper use, servicing, etc., so as to minimize risk.

⚠ WARNING

High voltages (up to 480 V) can kill. Always break the primary circuit to the power supply before starting to work on the heater and/or its wiring.

⚠ WARNING

Diffusion pumps are typically cleaned with acetone, alcohol, or other solvents.

When heated, sprayed or exposed to high temperature equipment, these solvents become flammable and explosive, causing serious injury or death. **Do not use near a high-temperature source.** Ventilate working area with a blower and use in large, well-ventilated room. When heated or sprayed, solvents also becomes 4 to 5 times heavier than air and will flow down, settling in tanks, pits, and low areas, thus displacing air which can kill by asphyxiation. Use in a large, well-ventilated room. Use of a self-contained breathing apparatus may be necessary.

Acetone, alcohol, and other solvents are irritants, narcotics, depressants, and/or carcinogenics. Their inhalation and/or ingestion may produce serious effects. Prolonged or continued contact with the skin will result in absorption through the skin and moderate toxicity. Always ensure that cleaning operations are carried out in large, well-ventilated rooms, and wear eyeshields, gloves, and protective clothing.

⚠ WARNING

Varian has no control over the types of gases passing through this pump. These are entirely under the control of the process user and/or the hardware systems integrator. Frequently, process gases are toxic, flammable, corrosive, explosive, or otherwise reactive. Since these gases can cause serious injury or death, it is very important to plumb the exhaust of the pump to the facility's hazardous gas exhaust system which incorporates appropriate filters, scrubbers, etc., to insure that the exhaust meets all air and water pollution control regulations.

⚠ WARNING

Certain gases can become corrosive and toxic when trapped in oil. Always wear protective gloves when handling dirty pump oil, drain it into a closable container, and do not breathe the fumes of the oil. Always use fully self-contained breathing apparatus.

▲ WARNING

If hazardous gas, vapors, chemicals, or combustible mixtures are pumped, sufficient quantities may exist during operation. This pump may contain decomposed and/or overheated pump oils or poisonous and/or overheated pump oils or poisonous and/or corrosive process materials which are highly toxic and also can be an asphyxiant. Proper operation will not always ensure that all hazardous materials have been removed.

▲ WARNING

Hot oils can cause serious burns. Wear protective gloves and long sleeved, loose fitting, heat resistant garments when draining pump oil.

▲ WARNING

When lifting some Varian diffusion pumps, use power-assisted equipment and trained moving/installation personnel to avoid dropping, slipping, and/or overturning the pump and severely injuring personnel. Check weight of equipment before lifting and do not stand under equipment being moved.

▲ CAUTION

Alcohol, acetone, and other solvents degrade O-ring materials reducing their ability to hold a vacuum. Do not use acetone or other solvents on O-rings. If necessary to clean O-rings, wipe with lint-free, clean cloth, wash in detergent and water, or use a small amount of pump oil.

Note

Always dispose of used or dirty oil properly and in compliance with all local, state, and federal environmental laws and regulations.

1-4 UNPACKING

Pumps are factory-packaged to permit prolonged storage in suitably protected areas without special precautions.

▲ WARNING

When lifting some Varian diffusion pumps, use power-assisted equipment and trained moving/installation personnel to avoid dropping, slipping, and/or overturning the pump and severely injuring personnel. Check weight of equipment before lifting and do not stand under equipment being moved.

- a. Remove flange covers, blank plugs, protective plugs from water connections, etc. Be careful not to scratch or otherwise damage or mar the sealing surface – usually an O-ring groove on top of the large inlet flange.
- b. Carefully remove the outer shipping container and save it for evidence if damaged. Notify the carrier immediately. Visually inspect the pump for damage that may have occurred during shipping. Discard any internal packing which may have been used to protect the internal components.
- c. For non-critical work, after making sure that there are no foreign materials inside the pump, it may be charged with fluid and used without disassembly. Otherwise, it should be disassembled and cleaned. In general, cleaning may be required if the expected vacuum level is to be below the 10^{-6} Torr (.000133 Pa) range.
- d. Check the internal jet assembly. It should be concentric and firmly seated on the bottom of the pump. The jet assembly should not rotate because of an indexing pin at the bottom.

1-5 CLEANING A NEW PUMP

- a. Read cold cap maintenance and installation data which will be found in Section III, para. 3-4, of this manual. Remove the cold cap in accordance with these instructions.
- b. Disassemble the internal jet system from the body of the pump. See Figure 3-2 for a section drawing of a typical jet assembly.
- c. Remove fill and drain plugs and gaskets if supplied.
- d. Thoroughly clean all components of the jet assembly and pump casing interior (but not O-ring gaskets) with acetone followed by an alcohol rinse.

▲ WARNING

Diffusion pumps are typically cleaned with acetone, alcohol, or other solvents.

When heated, sprayed or exposed to high temperature equipment, these solvents become flammable and explosive, causing serious injury or death. **Do not use near a high-temperature source.** Ventilate working area with a blower and use in large, well-ventilated room. When heated or sprayed, solvents also become 4 to 5 times heavier than air and will flow down, settling in tanks, pits, and low areas, thus displacing air which can kill by asphyxiation. Use in a large, well-ventilated room. Use of a self-contained breathing apparatus may be necessary.

Acetone, alcohol, and other solvents are irritants, narcotics, depressants, and/or carcinogenics. Their inhalation and/or ingestion may produce serious effects. Prolonged or continued contact with the skin will result in absorption through the skin and moderate toxicity. Always ensure that cleaning operations are carried out in large, well-ventilated rooms, and wear eyeshields, gloves, and protective clothing.

- e. Remove all traces of the cleaning fluid by carefully drying with clean, dry, oil-free compressed air.
- f. For reassembly, reverse the above procedure.
- g. Clean the flanges and O-ring grooves thoroughly with alcohol, using clean, lint-free rags.

▲ CAUTION

Acetone, alcohol, and other solvents degrade O-ring materials reducing their ability to hold a vacuum. Do not use solvents on O-rings. If necessary to clean O-rings, wipe with lint-free, clean cloth, wash in detergent and water, or use a small amount of pump oil.

- h. Remove all traces of acetone or alcohol by carefully drying with clean, dry, oil-free compressed air. Install O-ring gasket.

1-6 UTILITY AND SYSTEM CONNECTIONS

1-6-1 Safety Considerations and Interlocks

- a. Large pumps are equipped with two thermal switches. One is mounted at the body cooling coils, the other at the center of the boiler plate (at the bottom of the pump).

These thermal switches are supplied NORMALLY CLOSED. The thermal switches have been designed so that a cooling water failure or low oil level in the boiler will result in an increase in temperature, causing the NORMALLY CLOSED contacts of the switches to open. When the problem has been corrected and the temperature lowered, the thermal switch will automatically reset itself.

⚠ WARNING

Utility failure can cause damage to the equipment, overheating, and possible explosions. Designers of the equipment using diffusion pumps must design their system to protect personnel and property from possible hazards.

- b. A small lamp of the same voltage as the diffusion pump heater may be connected across the terminals of the thermal switch. The lamp will normally be shunted by the contacts. However, when the contacts open, the lamp will receive full line voltage and give a visual trouble indication.

1-6-2 Vacuum Connections

- a. The pump must be installed with the body vertical and plumb. Check that the mating flange on the system (to the pump inlet) is horizontal within plus or minus 1 degree. If this condition is not met, correct the system before installing the pump. The boiler of the pump (especially for large pumps) must be horizontal to prevent uneven fluid level and avoid local overheating where the fluid level would be too shallow.
- b. Prepare inlet O-ring seals by wiping them with a clean cloth. Do not use solvents. Use a small amount of diffusion pump oil to wet the cleaning cloth. Install the O-ring in the groove being careful not to damage the sealing surface with cuts, nicks, or scratches.
- c. Using appropriate lifting apparatus, align the bolt holes of the flanges and assemble the bolts. Tighten the bolts evenly to compress the O-ring seal until light contact is achieved between metal flanges.
- d. Check fill and drain plugs for tightness. Apply light to medium torque, enough to compress gaskets. Minute leaks through the gaskets may develop with use in this location. They may be detectable with very sensitive mass spectrometer leak detectors.

1-6-3 Cooling Water Connections (See Figure 1-3)

The following method of external connections is recommended.

- a. Water connections are designed for $\frac{3}{8}$ FPT fittings. The cold cap cooling coil and all of the body and foreline cooling (except the quick cool coil) should be connected in series. A cooling water supply of 3 to 4 gpm at 60°F to 80°F (16°C to 27°C) should be adequate. A higher flow than this will not be harmful.

The temperature at the discharged cooling water should not exceed 130°F (54°C). If the water supply pressure is low, it may be necessary to connect the different sections of cooling coils in parallel. This should be done if the cooling water discharge temperature exceeds 130°F (54°C). The cooling water discharge should, if possible, be connected to an open drain so that cooling water flow can readily be checked.

- b. The quick-cool coil at the boiler plate **MUST** be connected to an open drain and the feed line controlled by a separate water 3-way valve (open, closed, and vent to atmosphere). The drain must be below the boiler level so that it is drained completely when the quick-cool coil water supply is shut off and the pump is operating. See Figure 1-3.

1-6-4 Electrical Connections (See Figure 1-4a, b, c, d, or e Diffusion Pump Wiring Diagram)

⚠ WARNING

High voltages (up to 480V) can kill. Always break the primary circuit to the pump before starting to work on the heater and/or its wiring.

- a. The pump heater has been designed to operate at a certain voltage. Check the heater for correct supply voltage and, in the case of multiphase connections, for load balance by measuring the resistance of each branch.

Heater circuit resistance (all 3-phase, measured line-to-line)	200V – 3.3 ohms
	240V – 4.8 ohms
	460V – 17.6 ohms
	415V – 14.4 ohms
	480V – 19.2 ohms

- b. Make connections to the terminals in the junction box (at the foreline). The use of flexible conduit is recommended to facilitate removal of the pump for service. The pump should not be operated at more than 5% over the rated voltage. Make connections in accordance with the wiring diagram provided with each pump.

1-6-5 Thermal Switches

The thermal switches have been pre-set at the factory and should not require adjustment. The lower thermal switch is set at 550°F; the lower switch is set at 220°F. Should any thermal switch be thrown out of adjustment, it can be adjusted as follows.

1. Boiler thermal switch

The boiler thermal switch is mounted on a brass block at the center of the boiler. The thermal switch should be adjusted, with the pump operating, as follows:

- a) After several hours operation, disconnect the lead wires and place an ohmmeter across the terminals of the thermal switch.

1-6-6 Initial Vacuum Test

The purpose of this test is to establish the leak tightness of the system, specifically the vacuum connections to the diffusion pump. (To eliminate misleading indications and the masking of leaks by the fluid, the tests should be carried out with the diffusion pump “dry”, i.e., before it is charged with the pumping fluid.)

▲ WARNING

Pumps and their components are designed for vacuum service; they are not designed to be pressurized which could cause them to burst possibly expelling shrapnel at lethal velocities. Serious accidents have been caused by intentional pressurization of vacuum systems and their components. NEVER PRESSURIZE ANY PART OF A VACUUM SYSTEM FOR TEST OR ANY OTHER PURPOSE. Always provide pressure relief when designing diffusion pumps into systems and ensure that pressure relief motion is limited to safe envelopes.

- a Confirm the vacuum ultimate pressure characteristics of the mechanical pump. This should closely approximate the value quoted in the manufacturer’s data, if the mechanical pump is correctly installed, adjusted, and filled with clean oil. Pressure measurements should be made with a continuously indicating total pressure gauge, such as a thermocouple gauge. This test can be performed to evaluate either valved or unvalved systems. Connect the outlet or foreline of the diffusion pump to the inlet of the mechanical backing pump, using appropriate vacuum-tight connections.
- b In the case of a valved system, close the roughing valve and main isolation valve ahead of the diffusion pump. In the case of unvalved systems, the entire work chamber volume must be included in the test. Evacuate the entire system with the mechanical pump only.

Let the mechanical pump reach an ultimate pressure in the system. This reading should approximate the value obtained in step a above (usually 10 to 50 microns (1.33 to 6.65 Pa)). If it does not, examine for leakage. If leakage is suspected, follow standard procedures for leak testing. These will depend on the type of vacuum gauges and/or leak detection equipment available. The most effective are Varian’s helium leak detectors.

1-7 ADDING PUMP FLUID

WARNING

The risk of explosion in large pumps is increased by hydrocarbon oils, low fuel levels, or opening either fill or drain plugs during operation. Never operate diffusion pumps larger than 6 inches with hydrocarbon oils without a complete safety analysis for the specific system and application. Hydrocarbon oils are more prone to explode than synthetic silicone-based oils, similarly the larger the diffusion pump the greater the risk of explosion. Running the pump with low oil level causes hot surfaces and the oil to be decomposed and very toxic. Such decomposed oil and any residue from toxic/corrosive materials pumped will be present on the dipstick when the fluid level is measured.

NOTE

Fluids must be stored in clean, tightly closed containers and should be clearly identified in accordance with their type. Do not mix pumping fluids of different types and origins. Generally, it is not a good idea to mix used and new fluid for a pump charge.

- a. The recommended fluid charge for the pump is three gallons. The fluid charge will gradually be depleted through use, but the pump will continue to operate normally. When the charge is reduced to approximately 60% of the initial amount, the boiler temperature may begin to rise and under this condition the thermal switch is designed to open the heater circuit.
- b. This diffusion pumps is furnished with fill and drain fittings with special Viton elastomer sealed plugs.
- c. If the pump is hot, wait until the pump has cooled then vent it to atmosphere. Remove the plug from the filling port of the pump and install the specified quantity of fluid up to the FULL COLD level indicator on the sight glass (see Figure 1-5). The fluid can also be poured in from the pump inlet or foreline.
- d. Replace the fill plug with a new Viton gasket. Tighten the fill plug using moderate torque (75 inch-pounds maximum). Lubricate the O-ring with pump fluid before installation.
- e. Once the pump is running, the oil level should be in the FULL HOT operating range as indicated on the sight glass assembly.
- f. It is not recommended that SantoVac 5 Diffusion Pump Fluid be used with the HS-32.

SECTION II

OPERATION

During initial installation, the newly installed pump fluid may be subjected to a degassing process. This may result in foreline pressure fluctuations and “bursts”. Such fluctuations are considered normal.

2-1 START-UP PROCEDURE

▲ WARNING

The following conditions increase the risk of explosion:

- any air leaks into the system;
- roughing through a hot diffusion pump may cause some hot hydrocarbon fluids to ignite or explode when exposed to air;
- air release or admitting air to a pump with a hot boiler, permit a strong oxidizer to contact the hot pump oil;
- high (above 1 micron (.133 Pa)) inlet pressure;
- insufficient (or low level of) pump fluid;
- running pump without cooling water circulating to main water cooling coils;
- trapping water between closed isolation valves at inlet and discharge of quick cool coils and running diffusion pump;
- foreign matter in the pumping fluid which changes its viscosity and obstructs flow passages.

▲ CAUTION

- Do not turn on the heater without fluid in the pump. This may ruin the heaters and damage the pump.
- Do not air-release the pump while the boiler is hot. Most diffusion pump fluids are heat-sensitive and will break down under these conditions.
- Do not operate the pump without the foreline baffle. This may cause a greater than normal fluid loss.
- Do not operate the pump for extended periods at an inlet pressure above 1 micron. High pressure operation may cause excessive backstreaming.
- Do not operate the pump heater unless the cooling water is circulating. It will cause the pump and fluid to overheat.

- a. Evacuate the diffusion pump by means of the mechanical roughing pump to a pressure level below 0.5 Torr (66.5 Pa). The diffusion pump will not function unless the discharge pressure is less than the tolerable forepressure (approximately 0.5 Torr (66.5 Pa)).

Operation

- b. Turn on the cooling water supply to the pump body and check that adequate flow is provided by examining the amount of water discharged at the visual drain points.
- c. Switch on the power to the diffusion pump heater.
- d. Check inlet and forepressure performance by means of the system instrumentation.
- e. During operation, the gas load at the inlet of the diffusion pump should not exceed the maximum throughput capability of the pump. This means that the pressure at the inlet flange should not (except in transient conditions) exceed approximately 1×10^{-3} (.133 Pa) Torr. During operation, the discharge or fore pressure must be below the specified tolerable forepressure.

▲ WARNING

Boiler temperatures reach 530°F (275°C) which can cause serious burns when touched. Always ensure surfaces have cooled near room temperature before touching them.

Air release or admitting air to a pump with a hot boiler, especially when it is under vacuum, permits a strong oxidizer to contact the hot pump oil and thereby increases the risk of an explosion.

▲ CAUTION

Do not operate the quick-cool coil when the pump is cold or out of service to prevent harmful collection of condensation on the boiler plate, heater, and heater terminals.

2-2 SHUTDOWN PROCEDURE

- a. Switch off the power to the diffusion pump heaters.
- b. Admit cooling water to the quick-cool coil if necessary and continue to circulate it until the pump body just above the boiler heat shield can be touched (approximately 130°F or 54°C). In valved systems which have tight inlet and foreline connections, it is possible to close valves to isolate the diffusion pump at inlet and discharge, to air-release the remainder of the system, shut off the heat to the diffusion pump, and stop the mechanical pump. With this method, the quick-cool coil does not have to be used. However, the water flow through the pump must be maintained until the boiler cools down below approximately 300°F (150°C).

SECTION III

MAINTENANCE

3-1 GENERAL

Diffusion pumps generally require little attention when correctly operated. However, it is advisable to perform some periodic checks to insure continued trouble-free operation.

By simple preventive maintenance, costly down-time and cleaning procedures can be avoided. A day-to-day log of pump and system performance will indicate the condition of the pump and marked variations will show the need for corrective action.

3-2 PERIODIC INSPECTION

The frequency of inspection will depend on the type of system, its operation and utilization. The maximum interval between inspections is established on the basis of experience. It is recommended that the following items be regularly examined.

▲ WARNING

High voltages (up to 480V) can kill. Always break the primary circuits to the power supply before starting to work on the heater and/or its wiring.

Make sure that the pump is at room temperature before attempting service. Serious burns can result if this Warning is not heeded.

Depending on system process, poisonous or corrosive compounds may be present when opening the fill or drain. Always wear appropriate gloves and clothing and use a self-contained breathing apparatus.

An explosion could occur if the fill or drain is opened when the pump is running or when it is hot. Check oil level only when the pump is cold.

- a. When the pump is cold, check the condition and level of fluid. These can be inspected by withdrawing a sample through the drain and by visually checking the level of fluid through the sight glass respectively. (Use new O-ring gaskets when replacing fill and drain plugs.) Slight discoloration of the fluid does not affect performance.
- b. Loss of the fluid can be caused by the following:
 1. incorrect air admittance procedures and/or admittance of excessive air or other gas to a hot pump,
 2. inadequate water cooling, or
 3. continuous operation at inlet pressures above 10^{-3} Torr (.133 Pa).

Maintenance

- c. When the pump is cold, check that the heaters are bolted snugly to the boiler plate and that all heater terminal connections are tightly fastened inside the junction box.
- d. Check the total heater input and balance of load if a multi-phase heater is used.
- e. Check to insure that cooling water flow is unobstructed and not below specified quantities.

3-3 CLEANING

Complete cleaning of the pump may be periodically required because of the gradual deterioration of some pump fluids. Removal of the pump from the system is then necessary.

▲ WARNING

If hazardous gas, vapors, chemicals, or combustible mixtures are pumped, sufficient quantities may exist during operation. This pump may contain decomposed and/or overheated pump oils or poisonous and/or corrosive process materials which are highly toxic and also can be an asphyxiant. Proper operation will not always ensure that all hazardous materials have been removed.

Diffusion pumps are typically cleaned with acetone, alcohol, or other solvents.

When heated, sprayed or exposed to high temperature equipment, these solvents become flammable and explosive, causing serious injury or death. **DO NOT USE NEAR A HIGH-TEMPERATURE SOURCE.** Ventilate working area with a blower and use in large, well-ventilated room. When heated or sprayed, solvents also become 4 to 5 times heavier than air and will flow down, settling in tanks, pits, and low areas, thus displacing air which can kill by asphyxiation. Use in a large, well-ventilated room. Use of a self-contained breathing apparatus may be necessary.

Acetone, alcohol, and other solvents are irritants, narcotics, depressants, and/or carcinogenics. Their inhalation and/or ingestion may produce serious effects. Prolonged or continued contact with the skin will result in absorption through the skin and moderate toxicity. Always ensure that cleaning operations are carried out in large, well-ventilated rooms, and wear eyeshields, gloves, and protective clothing.

▲ CAUTION

Acetone and other solvents degrade O-ring materials reducing their ability to hold a vacuum. Do not use solvents on O-rings. If necessary to clean O-rings, wipe with a lint-free, clean cloth or use a small amount of diffusion pump oil.

3-5 DISASSEMBLING AND REASSEMBLING THE JET ASSEMBLY

1. To disassemble the jet assembly:
 - a Disassemble the cold cap water line feedthrough compression seals by removing the nut, follower, gasket, and female coupling located at the side of the pump. (See figure 3-2 for a section drawing of a typical jet assembly)
 - b Remove the block which secures the cold cap to the jet assembly.
 - c Lift out the cold cap.
 - d Unscrew the hex nut above the top cap and remove it.
 - e Lift the jet assembly out with a chain fall attached to the cross member now visible in the jet.
 - f Once the jet is out of the pump, unscrew the two nuts on the cross member to release the lower jet stages.
 - g Disassemble and clean as required.
2. To assemble the jet assembly:
 - a Reverse the steps outlined above.

3-6 HEATER REPLACEMENT

⚠ WARNING

High voltages (up to 480V) can kill. Always break the primary circuit to the power supply before starting to work on the heater and/or its wiring.

⚠ CAUTION

Poor clamping resulting in inadequate thermal contact may result in reduced heater life and poor pump performance. Tighten nuts finger-tight on clamping plate, then gradually and evenly tighten them to 250 in-pounds.

- a Determine which heater element has failed at the junction box, then disconnect the two corresponding leads from the terminal strip. Pull the leads out of the terminal box then out the elbow cover plate.

- b Remove the heater cover and insulation from the bottom of the diffusion pump.
- c Remove the nuts holding the clamping plate.
- d Lower the entire heating unit (heater element, clamping plate and heater shield, see Figure 3-3) until it is off the mounting studs.
- e Coat the boiler studs with anti-seize compound such as FEL-PRO-C-5A or common milk of magnesia.
- f Assemble the new unit (heater element, clamping plate, and crush plate).
- g Support the heating unit by the clamping plate, line up the holes with the boiler studs, and push the unit up against the boiler plate. Use two nuts finger-tight to hold it in place.
- h Screw on the remainder of the nuts finger-tight, then tighten the nuts evenly up to 250 inch-pounds of torque.
- i Label the heater leads according to the schematic diagram, then run the wires around the periphery of the pump, under the wire retaining clips, into the conduit, and up into the junction box. Connect the leads to the terminal strip then replace the elbow cover plate.
- j Replace the heater cover and insulation.

⚠ CAUTION

Should it be necessary to use a new wire in the following step, it is important that no. 10 stranded nickel wire with high-temperature insulation is used. The terminal lugs must be solid nickel. If copper or copper-plated wire and/or lugs are used, they will oxidize rapidly because of the high temperature and the terminals will overheat and fail.

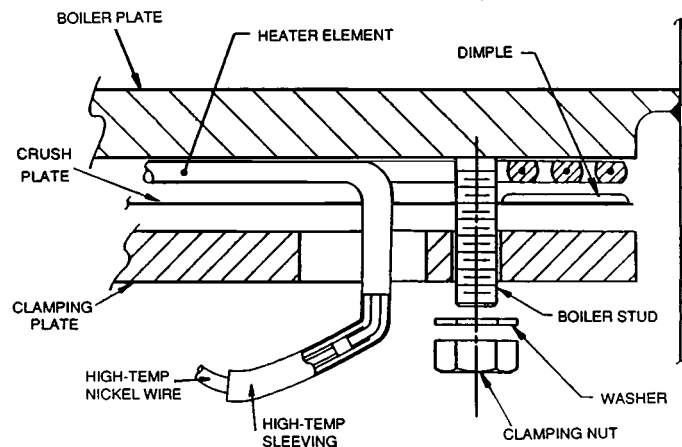

Figure 3-3. Heater Element Assembly



Health and Safety Clearance Return Authorization Policy

In compliance with Federal OSHA Safety Standard 1910.1200, Hazard Communications "Right to Know," Varian is enforcing that standard to preclude the potential health risk to its service personnel that can occur when receiving, disassembling, or repairing potentially contaminated products.

Returned products not accompanied by this completed certificate will be held until the completed certificate is received; failure to provide this completed certificate within 30 days of notification will result in the return of held product(s) **unprocessed**.

If a product is received at Varian in a contaminated condition, the customer will be held responsible for all costs incurred to ensure the safe handling of the product.

Company Name: _____

_____ Hereby certify that the product(s) listed below have been cleaned of all hazardous residue and that the residue remaining is of a non-hazardous nature.

_____ Hereby certify that the product(s) listed below have been contaminated by the following toxic or hazardous materials:

RA Number	Model Number	Serial Number
_____	_____	_____

_____	_____	_____
Authorized Signature	Title	Date

Note: Varian Service will only accept contaminated **Turbo or Mechanical Pumps**. All other products must be decontaminated by the customer before Varian Vacuum Products Lexington will assign a Return Authorization (RA) number and authorize the return of the product (refer to the attached Return Authorization Report on the next page).

Note: Varian Vacuum Products Lexington cannot accept any biological hazards, radioactive material, organic metals, or mercury at its facility.

Varian Vacuum Products
121 Hartwell Avenue
Lexington Massachusetts 02421
Telephone (781)861-7200
FAX (781)860-5405



VARIAN



VPD Service Operation

Returned Material Report

This report must accompany all products returned for repair, replacement, or warranty evaluation. Full information regarding reasons for return of the product will expedite repair or adjustment. Please fill in all blanks below and furnish any other information which will help identify the nature and cause of failure.

Reason for Return (check appropriate box)

- Paid Repair
- Advance Exchange
- Shipping Error
- Credit
- Warranty Evaluation
- Loaner Return
- Shipping Damage

Product Information (use separate forms if more than one model no.)

Varian Model No. _____ Serial No. _____ Quantity _____
 Part Description _____

Purchase Information (if product is being returned for warranty evaluation, show your original purchase order number and date purchased)

Varian Sales Order No. (if available) _____ Machine # _____
 Original Purchase Order No. _____ Purchase Order Date _____

Company Name _____ **Contact** _____

Address _____

City _____ **State** _____ **Zip** _____

Telephone _____

Failure Report (describe in detail suspected cause or nature of malfunction)

Returned Products

All products returned to Varian/VPD Service Operation for warranty evaluation must be sent **prepaid** and customer must comply with the **warranty replacement and adjustment** provision set forth in the warranty.

Ship directly to: Varian Vacuum Products
 Vacuum Products Service Center
 121 Hartwell Avenue
 Lexington, MA 02421

All products sold by Varian and returned by customer are subject to Varian Vacuum Products standard terms and conditions of sale including, but not limited to, the warranty and damages and liability provisions set forth in the warranty.